



MODEL  
**MANCHESTER**

TYPE  
**LED**

SERIES  
**ARCHITECTURAL**

**ZUMA LIGHTING LLC**  
325 N LARCHMONT BLVD STE 406, LOS ANGELES, CA 90004  
[INFO@ZUMALIGHTING.COM](mailto:INFO@ZUMALIGHTING.COM) • (310) 975-3126 • [ZUMALIGHTING.COM](http://ZUMALIGHTING.COM)

FIXTURE	WATTAGE	VOLTS	COLOR TEMP	OPTICS	LENS	MOUNT	COLOR	OPTIONS
MCH	16W = 2500lm to 2700lm  23W = 3500lm to 3800lm  34W = 4750lm to 5250lm  50W = 6500lm to 7100lm  62W = 7650lm to 8300lm  100W = 13150lm to 14300lm	U = 120v-277v  8 = 480v	27K = 2700K  3K = 3000K  4K = 4000K  5K = 5000K	T2 = Type II  T3 = Type III  T4 = Type IV  T5 = Type V	NL = No Lens <i>(open housing)</i>  CL = Clear Acrylic Lens  FL = Frosted Acrylic Lens	SF300 = post top  WM = wall mount	BZ8 = Zuma Bronze  BK = GT Black  WH = Alpine White  SL = Iridium Silver  GRY = Granite Gray  GRN = Moss Green  CC = Custom Specify RAL	M = Motion Sensor  PC = Photocell  D = Dimming  S = Surge Protection  LS = 180° Cutoff Shield

**ZUMA LIGHTING LLC**

325 N LARCHMONT BLVD STE 406, LOS ANGELES, CA 90004

[INFO@ZUMALIGHTING.COM](mailto:INFO@ZUMALIGHTING.COM) • (310) 975-3126 • [ZUMALIGHTING.COM](http://ZUMALIGHTING.COM) <sub>2</sub>

## Housing

The fixture housing is constructed from a combination of fabricated, cast, and spun aluminum.

## Electrical Components

High performance LEDs utilize state-of-the-art technologies for improved thermal performance. Available in Types II, III, IV, & V with wide choice of color temperatures ranging from CCT(2700K – 6500K). These LEDs are designed to fit LEDIL lenses with IP67 rating.

## Lens

Optional lens is available is fabricated from acrylic and can be specified clear or frosted.

## Finish

Thermoset polyester oven-baked powder coat, in any standard color. Custom colors are available to your specification. Marine grade finish available upon request.

## Certificates & Warranty

- ETL Listed
- Suitable for Wet Locations
- 5-Year Warranty

## Mounting

Fixture can be installed on post-top.

Tenon top mounting options:

- over 3" OD (standard)

Fixture can also be installed on mounting arms, sold separately. See architectural arm .pdf for style options.



**ZUMA LIGHTING LLC**

325 N LARCHMONT BLVD STE 406, LOS ANGELES, CA 90004

[INFO@ZUMALIGHTING.COM](mailto:INFO@ZUMALIGHTING.COM) • (310) 975-3126 • [ZUMALIGHTING.COM](http://ZUMALIGHTING.COM)

NOTE: THE SUBMITTAL DRAWING HAS BEEN PRELIMINARY DESIGNED.  
ALL DIMENSIONS SHOWN MAY BE VARIED AFTER FINAL DESIGN

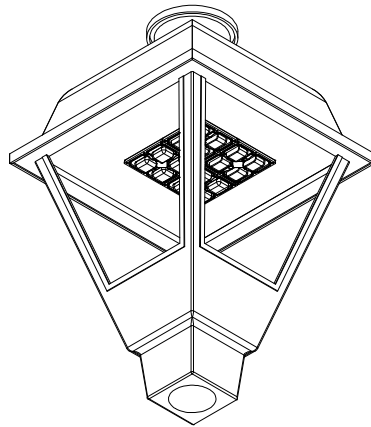
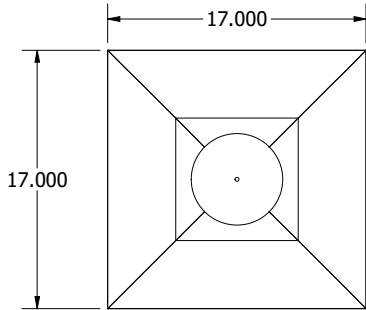

Heavy-duty Cast Aluminum Housing

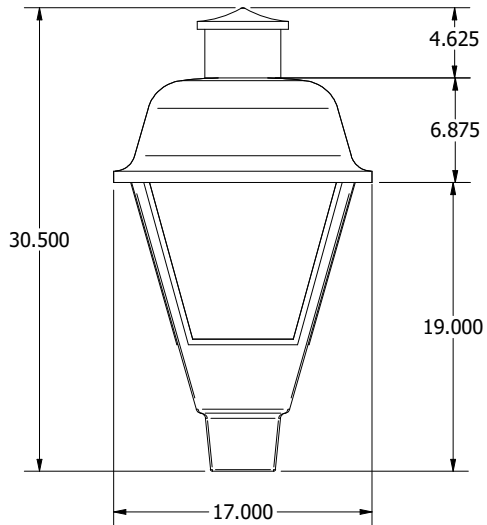
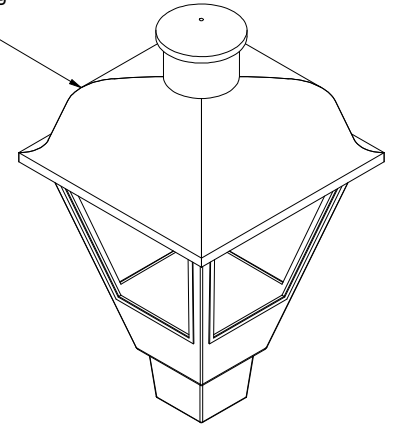

THESE PRINTS ARE SUBMITTED FOR YOUR APPROVAL PROCESSING OF YOUR PART WILL NOT COUNTINUE UNTIL WE RECEIVE ONE COPY APPROVED FOR PRODUCTION.

APPROVED BY:----- DATE-----

Approvals	DATE	These specifications and drawings are the property of Zuma Lighting and shall not be copied, reproduced as the basis for manufacture or sale of apparatus without permission	
Prepared:	6/7/2023		
Checked by:			
MFG			
APPROVED		TITLE	
Unless specified dimensions are in inches and Tolerances are: .XX= .03 .XXX= .010 Angles= 1/2'		Manchester LED Post-Top Fixture	
SIZE	DWG NO	REV	
B	Lantern Fixture	A	
SCALE	MAT'L	SEE NOTE	SHEET 1 OF 1

NOTE: THE SUBMITTAL DRAWING HAS BEEN PRELIMINARY DESIGNED.  
ALL DIMENSIONS SHOWN MAY BE VARIED AFTER FINAL DESIGN

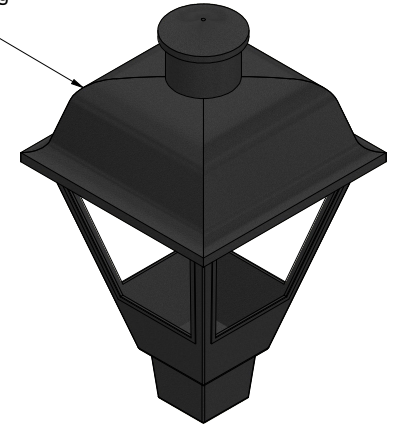
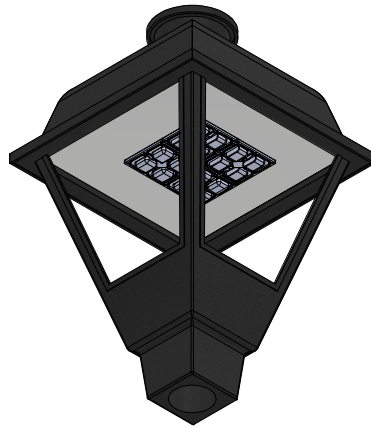
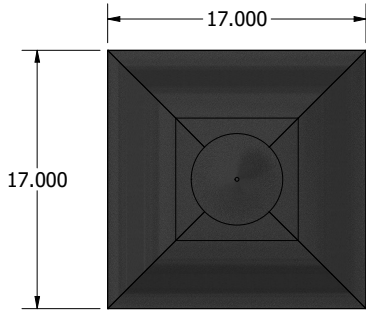

Heavy-duty Cast Aluminum Housing

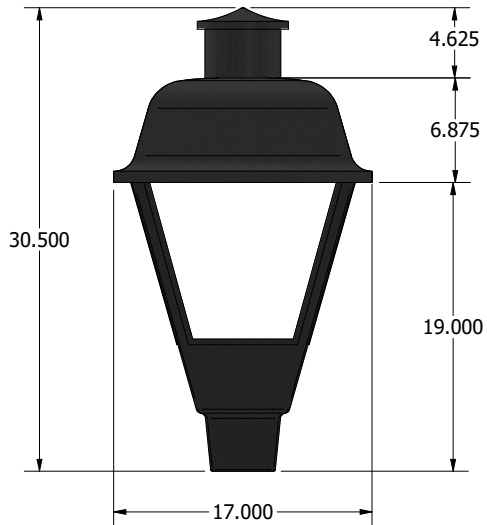

THESE PRINTS ARE SUBMITTED FOR YOUR APPROVAL PROCESSING OF YOUR PART WILL NOT COUNTINUE UNTIL WE RECEIVE ONE COPY APPROVED FOR PRODUCTION.

APPROVED BY:----- DATE-----

Approvals	DATE	These specifications and drawings are the property of Zuma Lighting and shall not be copied, reproduced as the basis for manufacture or sale of apparatus without permission	
Prepared:	6/7/2023		
Checked by:			
MFG			
APPROVED		TITLE	
Unless specified dimensions are in inches and Tolerances are: .XX= .03 .XXX= .010 Angles= 1/2'		Manchester LED Post-Top Fixture	
SIZE	DWG NO	REV	
B	Lantern Fixture	A	
SCALE	MAT'L	SEE NOTE	SHEET 1 OF 1